

Name: ROBERT BATLLE
Date: 10-12 FEBRUARY 2012
Track: MOTNPELLIER GP

Track Conditions

Size:	<input type="checkbox"/> Open	<input checked="" type="checkbox"/> Med.	<input type="checkbox"/> Tight
Traction:	<input type="checkbox"/> High	<input type="checkbox"/> Med.	<input checked="" type="checkbox"/> Low
Surface:	<input checked="" type="checkbox"/> Smooth	<input type="checkbox"/> Med.	<input type="checkbox"/> Bumpy

Front Suspension

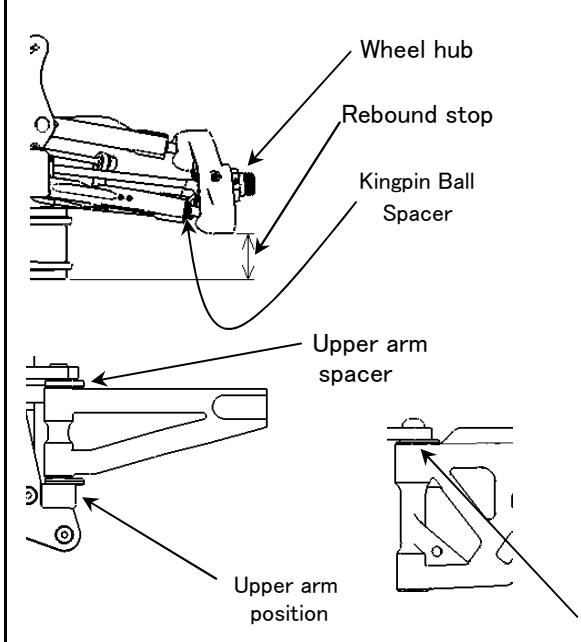

Kingpin ball spacer	<u>1</u> mm
Camber angle	<u>2</u> °
Upper arm spacer	<u>0</u> mm
Toe angle	<u>1</u> °
Rebound stop	<u>NO</u> mm
Anti-roll bar	<u>φ 2,3</u> mm
Wheel Hub	<u>1</u> mm
Lower arm mount (Kick up)	<input type="checkbox"/> 0 <input checked="" type="checkbox"/> 1
Lower arm plate (E0154A)	<input checked="" type="checkbox"/> <input type="checkbox"/>
Upper arm position (E0148B, E0148C)	<input type="checkbox"/> <input checked="" type="checkbox"/> <input type="checkbox"/>
Lower arm spacer	<u>0</u> mm

Front Shocks

Piston	<u>STD</u>
Oil	<u># 45 UR</u>
Spring	<u>9,75 BLACK</u>
Spring adjustment	<u> </u> mm

Shock position

Steering Ackerman



Rear Suspension

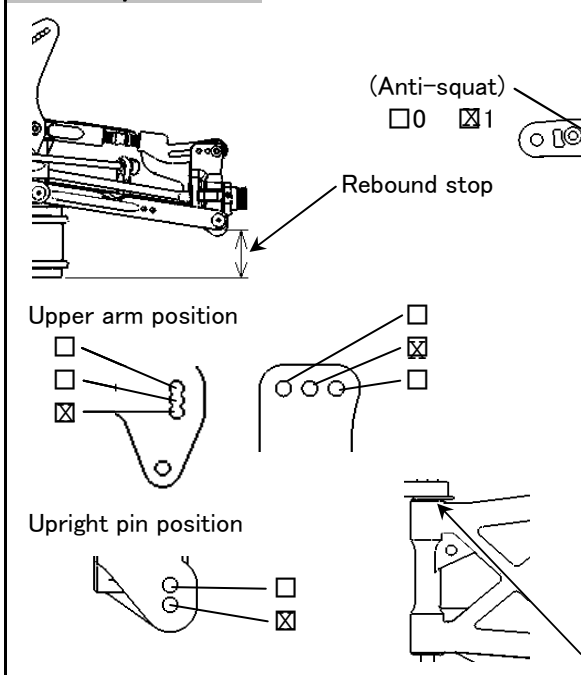

Camber angle	<u>2</u> °
Lower arm mount	<input checked="" type="checkbox"/> E0185(Aluminium)
(Anti-squat)	<input type="checkbox"/> 0 <input checked="" type="checkbox"/> 1
(Toe angle)	<u>2,5</u> °
Rebound stop	<u>NO</u> mm
Anti-roll bar	<u>φ 2,8</u> mm
Anti-squat (E0111C, E0111D)	<input type="checkbox"/> <input type="checkbox"/> <input checked="" type="checkbox"/>
Upright	<input checked="" type="checkbox"/> E0152 <input type="checkbox"/> E0173(Aluminium)
Wheelbase adjustment	<u>2</u> mm
Lower arm spacer	<u>1</u> mm

Rear Shocks

Piston	<u>STD</u>
Oil	<u># 40 UR</u>
Spring	<u>10,5 BLACK</u>
Spring adjustment	<u> </u> mm

Shock position

Wing Position

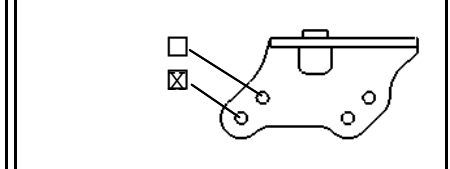

Engine Type NOVAROSSO BONITO

Gasket	<u> </u> mm	Reducer	<u>φ 5,4</u>
Plug	<u>C6TGC</u>	Fuel	<u>MERLIN</u>
Muffler	<u>9901</u>		

Diff. Oil

Front	# <u>7000</u>	O-Ring	<u>NO</u> pcs. <input type="checkbox"/> Other <u>UR</u>
Center	# <u>7000</u>		<u>NO</u> pcs. <input type="checkbox"/> Other <u>UR</u>
Rear	# <u>3000</u>		<u>NO</u> pcs. <input type="checkbox"/> Other <u>UR</u>

Tire

Front	Rear
Type <u>HOT DICES RED</u>	Type <u>HOT DICES RED</u>
Foam <u>YELLOW STD</u>	Foam <u>YELLOW STD</u>

Clutch

Clutch shoes	<input checked="" type="checkbox"/> Aluminium
UR COMPAK V2 B9.5	<input type="checkbox"/> Other <u> </u>
Spring	<u>9,5</u> mm
Clutch bell / Spur gear	<u>13 T / 46T</u>

Result

Race time / Lap

Best lap (1Lap)

Comments:

RIDE HEIGHT 23mm FRONT 26mm REAR

DIF GEAR 12/42 FRONT AND REAR

NEW MBX-6R EU SPEC REAR SHOCK TOWER